

TOYOTA PRIUS GROUND EFFECTS KIT 2012 -

Preparation

Part Number: PT938-47120-XX

Kit Contents

Item #	Quantity Reqd.	Description
1	1	LH & RH FRONT SKIRTS
2	1	LH & RH SIDE SKIRTS
3	1	LH, RH, CENTER REAR SKIRTS
4	1	HARDWARE KIT

Hardware Bag Contents

Item #	Quantity Reqd.	Description
1		
2		
3		
4		

Additional Items Required For Installation

Item #	Quantity Reqd.	Description
1	1	ENGINE UNDER COVER
2	2	PLASTIC SCREW GROMMET
3	1	PLASTIC WING NUT

Conflicts

--

Recommended Tools

Personal & Vehicle Protection	Notes
Safety Glasses	
Special Tools	Notes
Rivet gun	
Spray Bottle	To hold soapy water
Installation Tools	Notes
Drill	4.5 mm Drill bit
Drill Stop	25mm from top
Plastic Pry tool	To remove push pins
10mm socket	Ratchet
10mm ratchet wrench	
Special Chemicals	Notes
Soapy Water solution	

General Applicability

--

Recommended Sequence of Application

Item #	Accessory
1	Front skirts
2	Rear skirts
3	Side skirts





*Mandatory

NOTE: Part number of this accessory may not be the same as the part number shown.

Vehicle Service Parts (may be required for reassembly)

Item #	Quantity Reqd.	Description
1	1	PT938-47100-RR REAR SKIRT KIT
4	1	PT938-47100-SL SIDE SKIRT LEFT
5	1	PT938-47100-SR SIDE SKIRT RIGHT
6	1	PT938-47120-FL FRONT SKIRT LEFT
7	1	PT938-47120-FR FRONT SKIRT LEFT

Legend

	STOP: Damage to the vehicle may occur. Do not proceed until process has been complied with.
	OPERATOR SAFETY: Use caution to avoid risk of injury.
	CAUTION: A process that must be carefully observed in order to reduce the risk of damage to the accessory/vehicle and to ensure a quality installation.
	TOOLS & EQUIPMENT: Used in Figures calls out the specific tools and equipment recommended for this process.
	REVISION MARK: This mark highlights a change in installation with respect to previous issue.

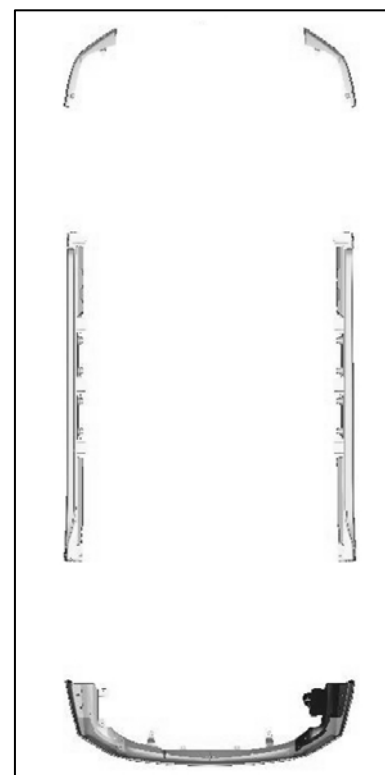

TOYOTA PRIUS GROUND EFFECTS KIT 2012 -

Preparation

Front Skirts

Kit Contents

Item #	Quantity Reqd.	Description
1	1	LH FRONT SKIRT
2	1	RH FRONT SKIRT
3	1	BRACKET KIT
4		

Hardware Bag Contents

Item #	Quantity Reqd.	Description
1	12	Rivets
2	2	U-nut
3	2	Self Tapping Screw
4		

Additional Items Required For Installation

Item #	Quantity Reqd.	Description
1	Roll	50mm Masking Tape

Conflicts

--

Recommended Tools

Personal & Vehicle Protection	Notes
Safety Glasses	
Special Tools	Notes
Rivet gun	
Spray Bottle	To hold soapy water
Installation Tools	Notes
Drill	4.5 mm Drill bit
Drill Stop	25mm from top
Plastic Pry tool	To remove push pins
10mm socket	Ratchet
10mm ratchet wrench	
Special Chemicals	Notes
Soapy Water solution	

General Applicability

--

Recommended Sequence of Application

Item #	Accessory
1	
2	
3	





*Mandatory

NOTE: Part number of this accessory may not be the same as the part number shown.

Vehicle Service Parts (may be required for reassembly)

Item #	Quantity Reqd.	Description
1		
2		
3		

Legend

	STOP: Damage to the vehicle may occur. Do not proceed until process has been complied with.
	OPERATOR SAFETY: Use caution to avoid risk of injury.
	CAUTION: A process that must be carefully observed in order to reduce the risk of damage to the accessory/vehicle and to ensure a quality installation.
	TOOLS & EQUIPMENT: Used in Figures calls out the specific tools and equipment recommended for this process.
	REVISION MARK: This mark highlights a change in installation with respect to previous issue.

TOYOTA PRIUS GROUND EFFECTS KIT 2012

Procedure

Care must be taken when installing this accessory to ensure damage does not occur to the vehicle. The installation of this accessory should follow approved guidelines to ensure a quality installation.

These guidelines can be found in the "Accessory Installation Practices" document.

This document covers such items as:-

- Vehicle Protection (use of covers and blankets, cleaning chemicals, etc.).
- Safety (eye protection, rechecking torque procedure, etc.).
- Vehicle Disassembly/Reassembly (panel removal, part storage, etc.).
- Electrical Component Disassembly/Reassembly (battery disconnection, connector removal, etc.).

Please see your Toyota dealer for a copy of this document.

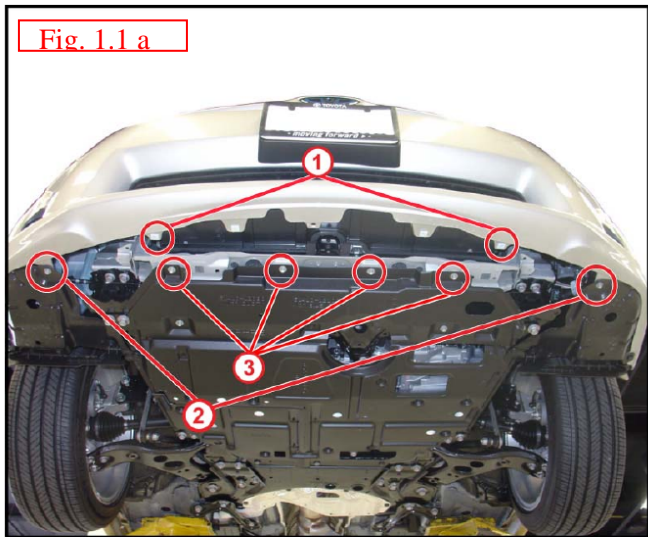

1	Plastic Screw Grommets
2	Self-tapping Screws
3	Bolts

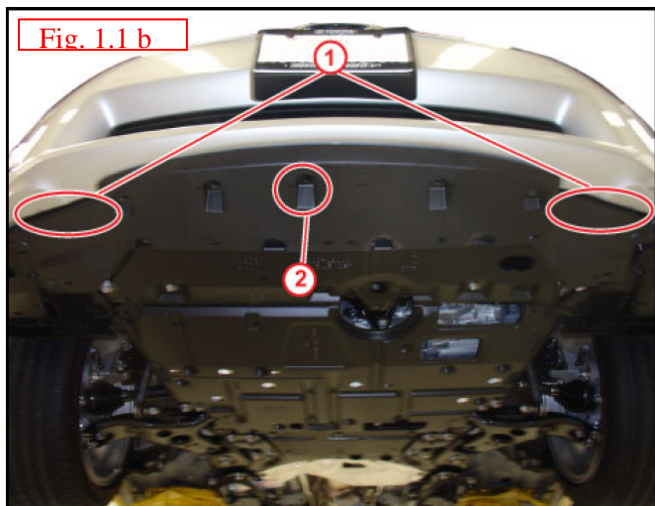

1	Lips of Front Spoiler Under Cover
2	Plastic Retainer Clip

1. Front Spoiler undercover Installation (Preparation for Front Skirt)

- (a) Remove the front spoiler undercover from the luggage compartment and associated hardware.
- (b) Clean all bumper surfaces before beginning installation.

(c) Front spoiler undercover Installation

- i. Remove the self tapping screws (#2) from the front wheel assembly and save them for later use with the front skirts install. (Fig 1.1a)

Remove the four bolts (#3) from the engine undercover.(Fig 1.1a)

- ii. Install 2 plastic screw grommets into bumper as shown in Fig.1.1a marked "1"
- iii. Fig 1-1b; Place both lips of the front spoiler undercover into the bumper cover. Install the plastic retainer clip into the center hole.

TOYOTA PRIUS GROUND EFFECTS KIT 2012

Procedure

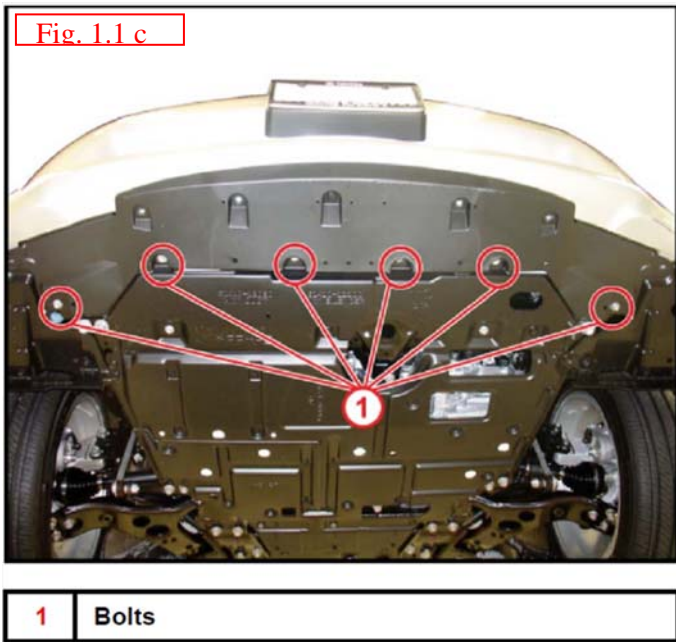

(d) Install the 2 bolts removed from the kit and the 4 bolts removed from the engine undercover into the back of the front spoiler undercover. (Fig 1-1c)

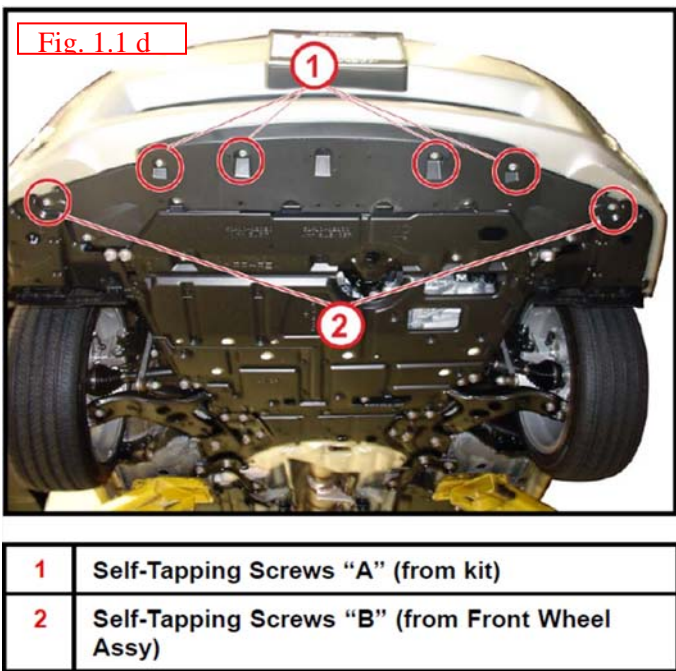

(e) Install the four self tapping screws in the location marked "1" Fig 1-1d

Do not install the self tapping crews in location marked "2" they will be used for the Front skirt.

TOYOTA PRIUS GROUND EFFECTS KIT 2012

Procedure

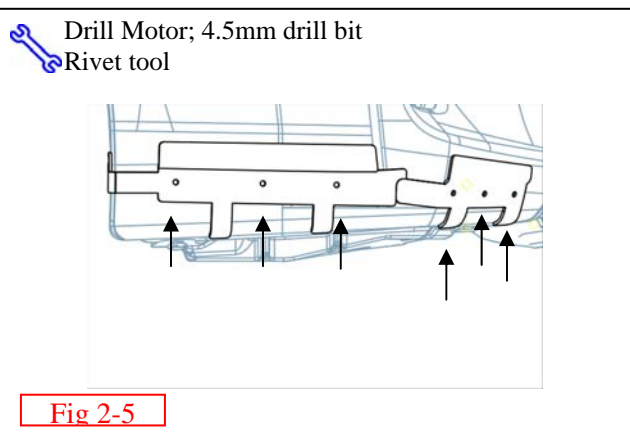
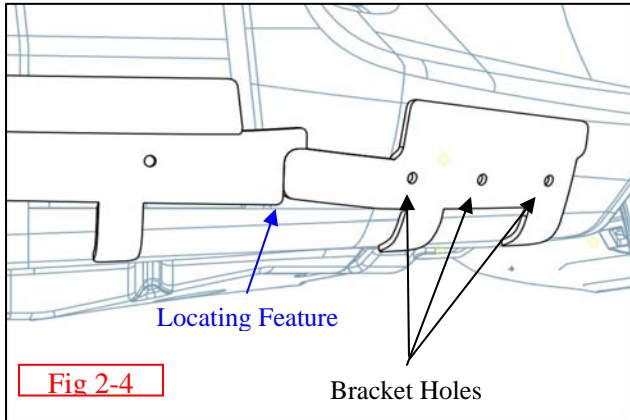
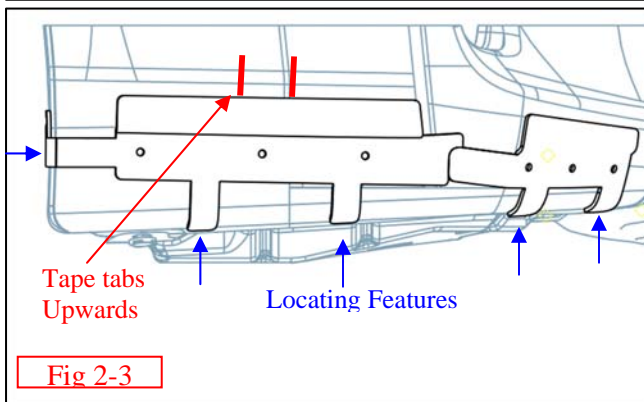
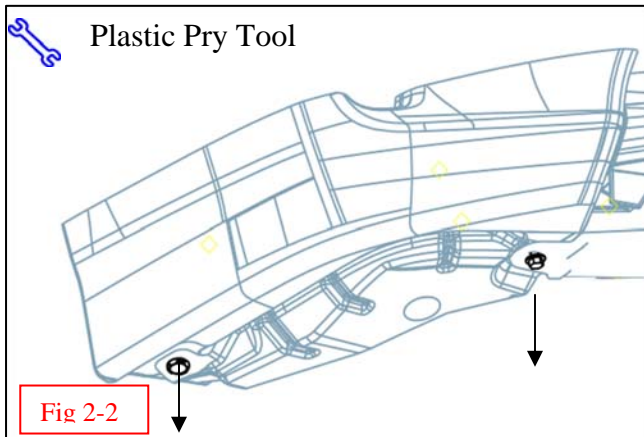

2. Front Skirt Installation

- ⚠ (a) Remove the plastic retainer clip in the sides.
- (b) Unpack kit contents and locate 4 installation brackets.
- (c) Ensure the tape tabs are folded upward and accessible, do not peel off yet; see sample on fig 2-3.
- ⚠ (d) Place brackets on the vehicle by aligning the **locating features in bracket** with vehicle surface, and each other. Start with the one closer to the tire. (fig 2-3 & 2-4)
- (e) Once bracket is located, hold it in place and pull away tabs. This will stick the bracket to the vehicle. Do not hold it too tight or the tape tab might break and the adhesive will not be exposed. If this happens, remove bracket; remove broken tab and replace.
- ⚠ (f) Repeat for brackets on opposite side of vehicle.
- (g) Once all brackets are adhered to vehicle, locate 4.5 mm drill.



Before drilling, make sure the bracket it is seated properly on the vehicle features (the bracket conforms to the vehicle surface); be sure to hold bracket firmly in place while drilling, and drill perpendicular to the surface. Drill holes through existing bracket holes (Fig2-4 & 2-5)

- (h) Locate hardware pack and retrieve 12 rivets. Using rivet gun apply rivets in 12 places as shown. (fig 2-5)

TOYOTA PRIUS GROUND EFFECTS KIT 2012

Procedure

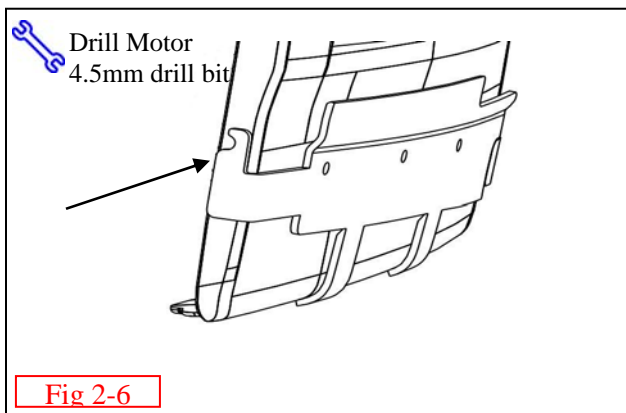

- (i) Using the bracket locating feature on the fender well side as a drill guide; drill 4.5mm hole in both fenders (Fig 2-6)
- (j) Snap off all locating features on brackets and discard pieces.

3. Skirt Installation

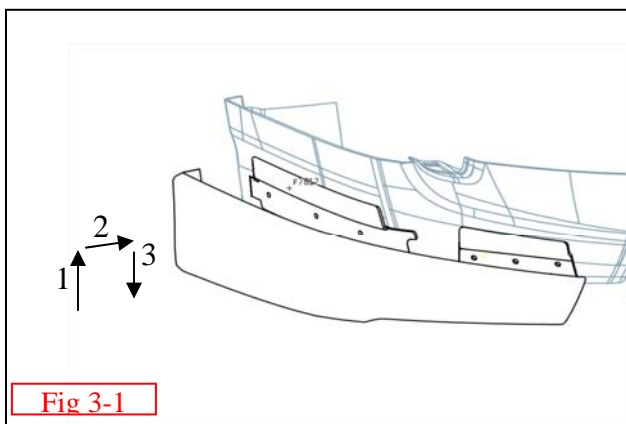

Apply a strip of masking tape approx 10 mm above vehicle brackets to protect the vehicle paint during installation.

- (a) Spray bumper surfaces above brackets with soapy water. Each of the skirts will be snapped on in 2 steps. First the outside snaps, then the front snaps.
- (b) Locate front skirt.

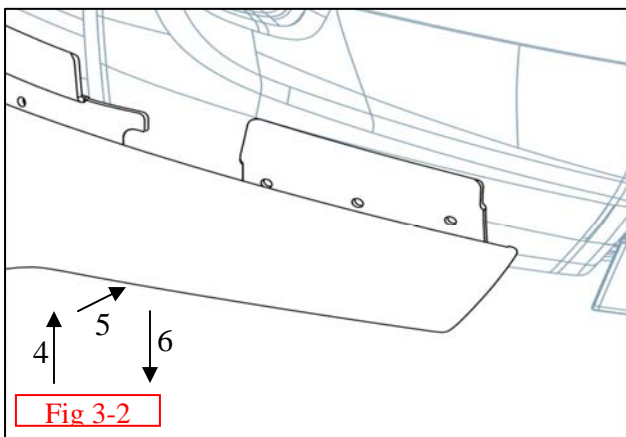

- (c) Fig 3-1: By using some force press upward and against fender well(1) and inward(2) **making sure the tabs have cleared the bracket hooks (for proper installation and avoid damage to tabs)**. Then downward(3) against the vehicle to snap in position



- (d) Once the outside surface is in place: Move to the front of the skirt (Fig 3-2). While holding the outside surface so it does not disengage, press upward(4) and inward(5) (to clear the bracket hooks); then press downward(6) to snap in place

NOTE: The engagement might be done in reverse order, if it's easier for the installer

Issue: B

TOYOTA PRIUS GROUND EFFECTS KIT 2012

Procedure

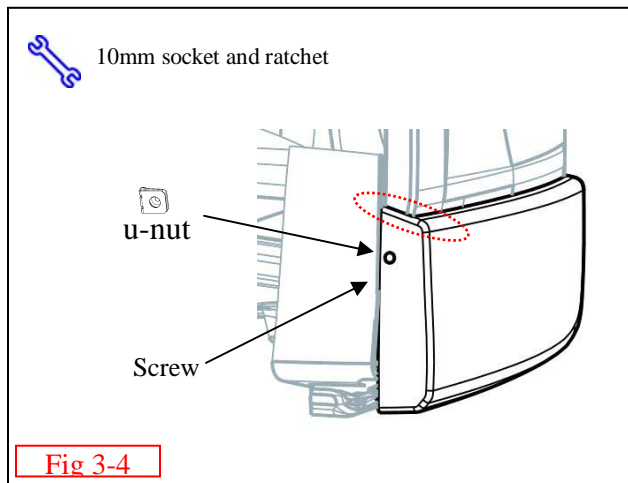
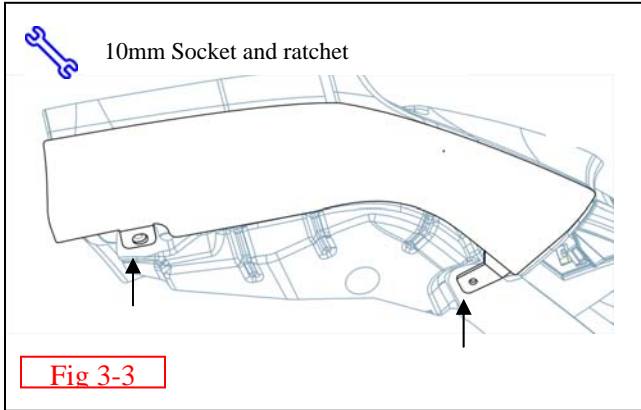

(e) Once this is complete ensure the skirt is firmly in place; all tabs are engaged and there are no gaps between the rubber seal and the vehicle

(f) Install vehicle screw and push pins (Fig 3-3)

(g) Insert 1 u-nut per side over hole drilled on fender well in step (i) and in between the fender and skirt. (flat side towards skirt)

NOTE: A gap of less than 2mm between fender and skirt (red oval Fig.3-4) will be present due to the u-nut, this is expected.

(h) Locate 6.3x 20mm self tapping screw from hardware bag and install into the fender well through the skirt and u-nut. Fig 3-4.

(i) Tighten all fasteners to ensure are flat against surface.

(j) Repeat For Other Side

TOYOTA PRIUS GROUND EFFECTS KIT 2012 - Preparation

Accessory Function Checks

- Visual check of Front Skirt
 - Make sure all fasteners are in place
 - Check for overall appearance

-  Re-check all screws and bolts

Check to ensure there are no gaps between the rubber seal (gasket) and the vehicle surface.

Check if brackets are engaged by lightly tapping on the skirts and listening for looseness.

TOYOTA PRIUS GROUND EFFECTS KIT 2012 -

Preparation

Rear Skirts

NOTE: Part number of this accessory may not be the same as the part number shown.

Kit Contents

Item #	Quantity Reqd.	Description
1	1	REAR SKIRT LH
2	1	REAR SKIRT INNER CLOSE OUT - LH
3	1	REAR SKIRT RH
4	1	REAR SKIRT INNER CLOSE OUT - RH
5	1	REAR SKIRT CENTER
6	1	MOUNTING BRACKET KIT

Vehicle Service Parts (may be required for reassembly)

Item #	Quantity Reqd.	Description
1		
2		
3		

Hardware Bag Contents

Item #	Quantity Reqd.	Description
1	2	PLASTIC CLIPS
2	27	RIVETS
3	4	Self Tapping Screw
4	2	6.3 U-NUT
5	2	6.3X40mm TAPPING SCREW

Additional Items Required For Installation

Item #	Quantity Reqd.	Description
1	ROLL	50mm MASKING TAPE

Recommended Tools

Personal & Vehicle Protection	Notes
None	
Safety Glasses	
Special Tools	Notes
Rivet Gun	
Spray bottle	
Installation Tools	Notes
Drill	4.5 mm Drill bit
Drill Stop	25mm from top
Plastic Pry tool	To remove push pins
10mm socket	Ratchet
10mm ratchet wrench	
Special Chemicals	Notes
Soapy water solution	

General Applicability

--

Recommended Sequence of Application

Item #	Accessory
1	REAR SKIRT LH LH & RH
2	REAR SKIRT CENTER
3	CLOSE OUTS

*Mandatory

Legend



STOP: Damage to the vehicle may occur. Do not proceed until process has been complied with.



OPERATOR SAFETY: Use caution to avoid risk of injury.



CAUTION: A process that must be carefully observed in order to reduce the risk of damage to the accessory/vehicle and to ensure a quality installation.



TOOLS & EQUIPMENT: Used in Figures calls out the specific tools and equipment recommended for this process.



REVISION MARK: This mark highlights a change in installation with respect to previous issue.

TOYOTA GROUND EFFECTS KIT 2012 -

Procedure

Care must be taken when installing this accessory to ensure damage does not occur to the vehicle. The installation of this accessory should follow approved guidelines to ensure a quality installation.

These guidelines can be found in the "Accessory Installation Practices" document.

This document covers such items as:-

- Vehicle Protection (use of covers and blankets, cleaning chemicals, etc.).
- Safety (eye protection, rechecking torque procedure, etc.).
- Vehicle Disassembly/Reassembly (panel removal, part storage, etc.).
- Electrical Component Disassembly/Reassembly (battery disconnection, connector removal, etc.).

Please see your Toyota dealer for a copy of this document.

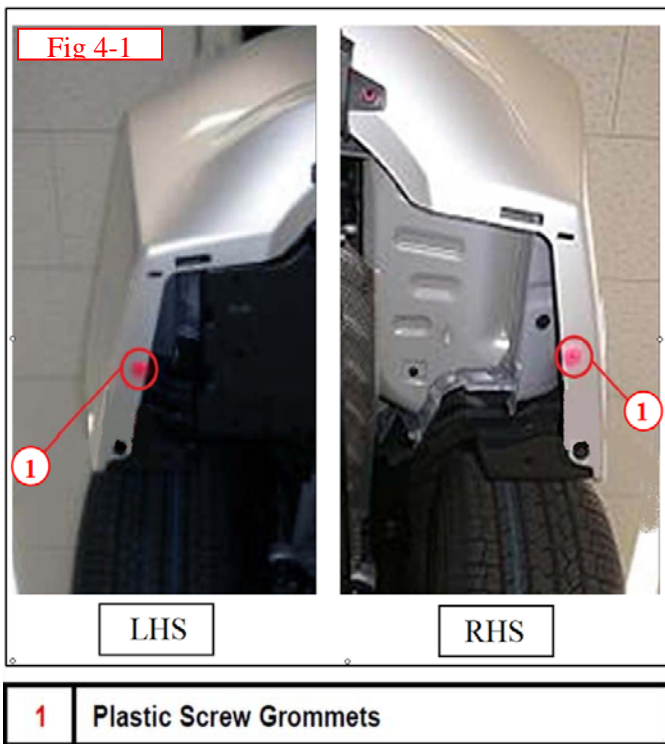

4. Rear Spoiler (Preparation for Rear Skirt)

- Remove the rear side spoiler kit LH & RH from the luggage compartment and associated hardware.
-  From RH spoiler kit extract the 2 (pink) and the Plastic Wing Nut (for later use)
- Install the plastic screw grommets in LH and RH sides in location shown in figure 4-1.
- Remove the plastic retainer clips shown on Figure 4-2 (save for later use) and remove rear center spoiler.
- Discard LH, RH, and Center spoilers as well as all remaining hardware
- Clean Vehicle surfaces.
- Unpack rear Body kit.

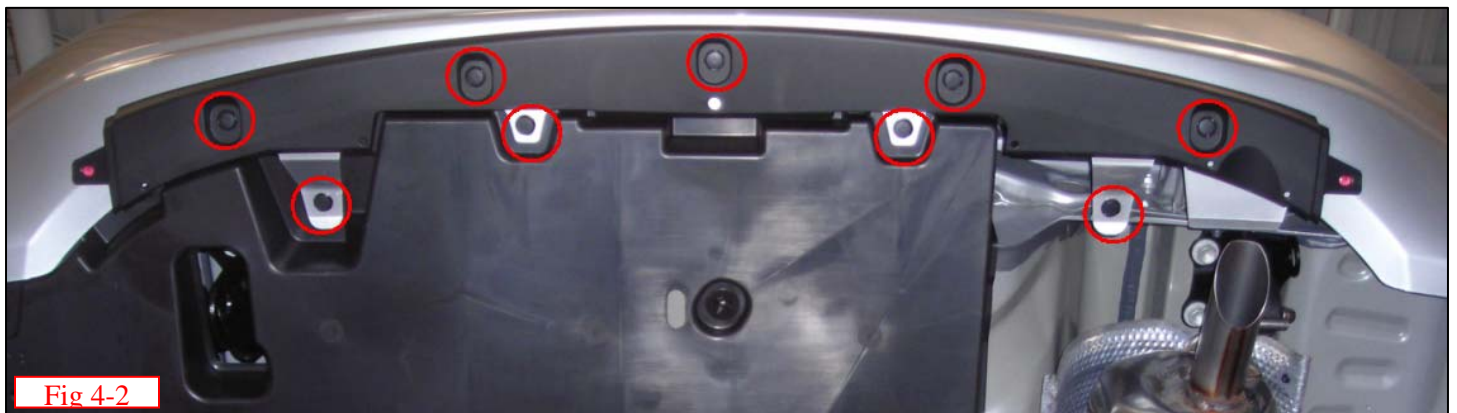

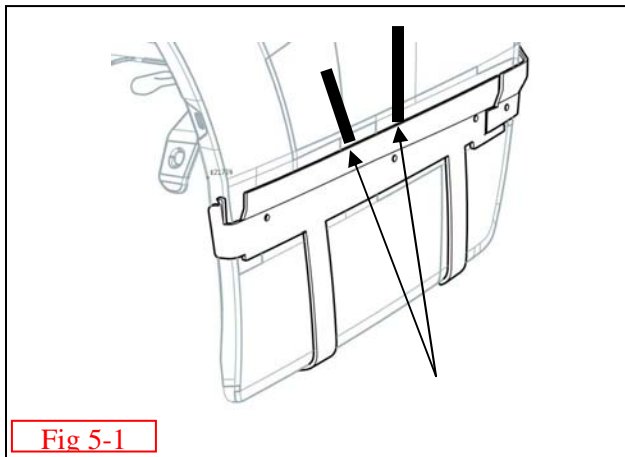

Fig 5-1

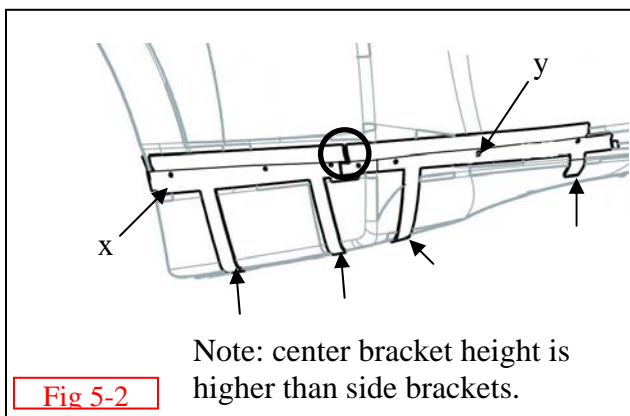

Fig 5-2

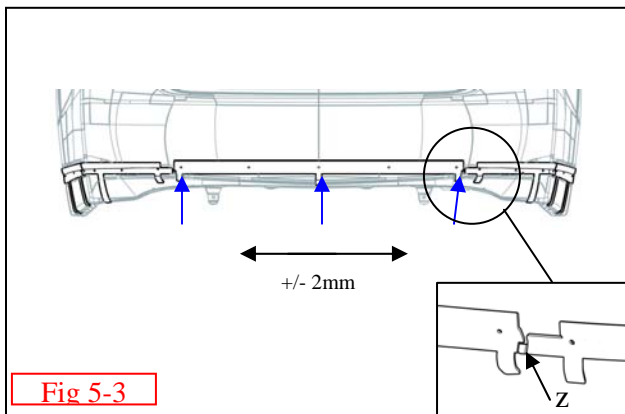

Fig 5-3

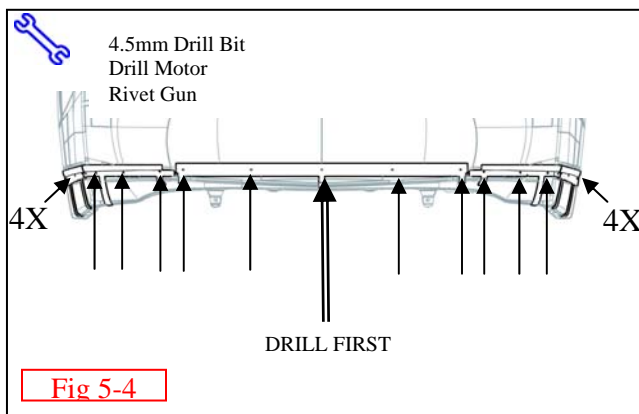

Fig 5-4

5. Rear Skirt Installation

NOTE: To achieve proper part location the sequence below must be followed.

(a) Locate side skirt rear mounting bracket "x". Apply as shown in figure 5-1 & 5-2 .Bracket tabs will conform to vehicle



(b) Ensure the tape tabs are folded upward and accessible, do not peel off yet; see sample on fig 5-1

(c) Peel tape while holding bracket in place. Do not hold it too tight or the tape tab might brake and the adhesive will not be exposed. If this happen, remove bracket; remove broken tab and replace.

(d) Fig 5-2: Bracket "y" will locate to vehicle on side to side direction and to bracket "x" for the up-down; To proper locate bracket "y" push on vehicle "surface corner" and make sure is mating with bracket "x" bottom tab.

(e) Peel tape same as previously explained

(f) Repeat procedure for RHS



(g) Locate rear center mounting bracket. to the vehicle features Fig 5-3, then center bracket between RH and LH rear mounting brackets ensuring a even gap between both (+/- 2mm). If additional space is required between brackets tabs "z" (due to bumper size), they can be broken. Once aligned hold center bracket in position and peel tape tabs for a temporary hold.

(h) Once all brackets are adhered to vehicle, locate 4.5mm drill bit and drill motor.



Before drilling, make sure the bracket is centered and is seated properly on the

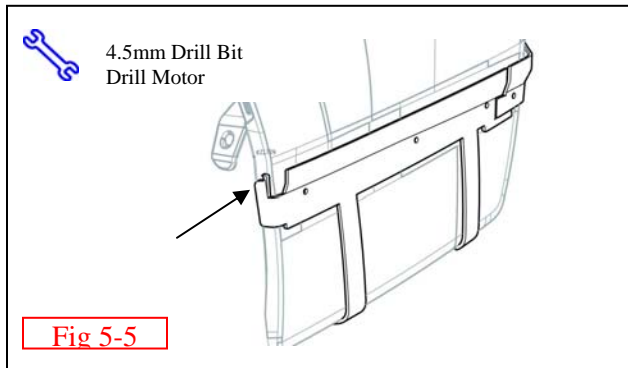

Fig 5-5

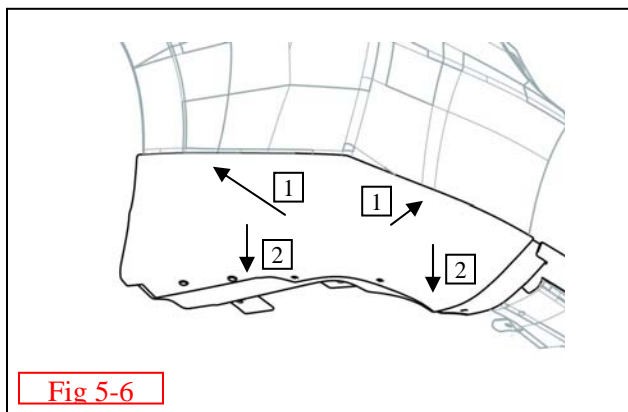

Fig 5-6

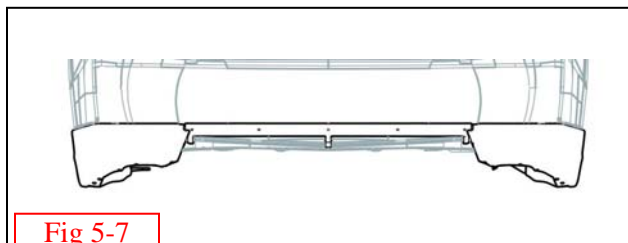

Fig 5-7

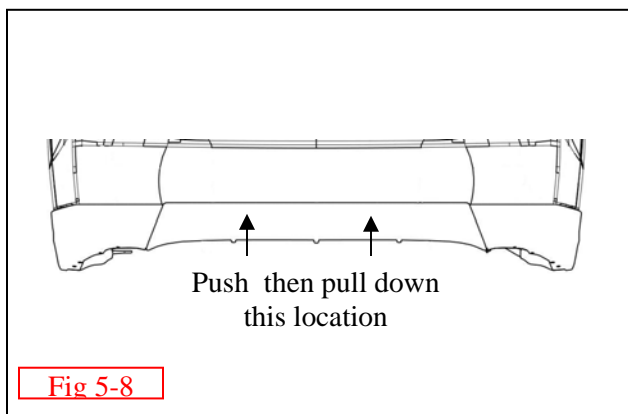

Fig 5-8

vehicle features (the bracket conforms to the vehicle surface); be sure to hold bracket firmly in place while drilling, and drill perpendicular to the surface.

NOTE: start drilling middle hole to further enhance alignment

Drill the holes through existing bracket holes. Once all holes are drilled obtain rivets from the supplied hardware bag and rivet the mounting brackets to the bumper; one rivet per hole. Fig 5-4

- (i) Using bracket locating feature on the fender well side as a drill guide, drill 4.5mm hole in both fenders (Fig 5-5); drill through both pieces of plastic.

! Break off all locating tabs from the brackets and discard.

- (k) Apply a 50mm in wide strip of masking tape 10-15 mm above the mounting brackets before installing rear skirts.

- (l) Locate rear LH skirt; spray the bumper area above the brackets with a soapy water solution. Install the side skirt by pushing up and in see arrows(1) on the part **make sure to clear all tabs** and then bringing the entire part down (2) so that the **tabs engage to the bracket.** (Fig.5-6) Check the part for looseness and gapping. **Do not install any hardware yet.**

- (m) Repeat for the RHS.

- (n) Once RH and LH are installed (Fig.5-7) Locate the rear center skirt. Spray area above the mounting bracket with soapy water. Install skirt by pushing up and in on the part Fig.5-8; making sure the tabs are clear and the part centered. Then bringing the entire

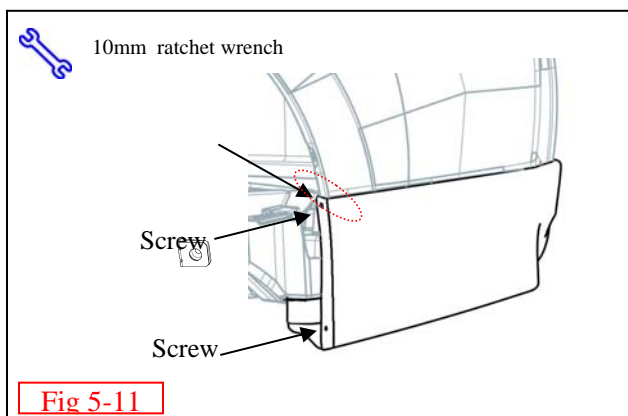
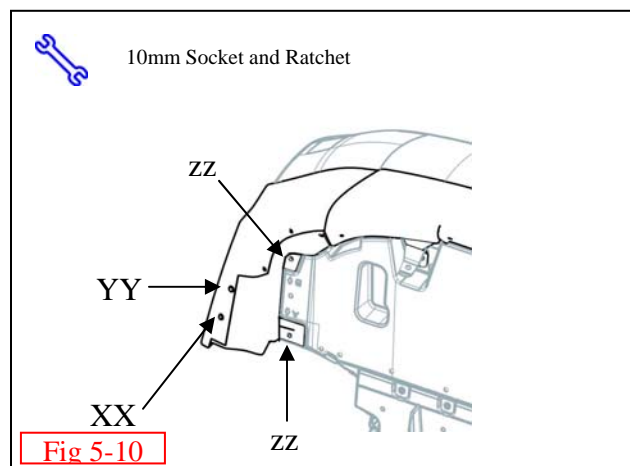
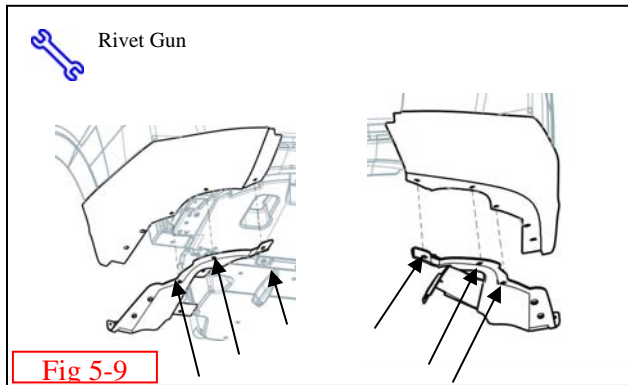

part down so that the tabs engage to the bracket. Making sure all the tabs engaged. **Check side to side alignment is +/- 2mm.**

(o) CLOSE OUT PIECES Installation

Locate and install rear LH & RH close down pieces Inner pieces. Line up rivet holes shown on Fig. 5.9 as well as the locating boss “XX” and the screw hole “YY” shown on Fig 5-10. Ensuring rivet holes are lined up install 3 rivets per side to connect the parts together. Install the 6.3x40 screws “YY” (Fig.5-10) these screws have to engage in the plastic screw grommets (pink); It is helpful to pull down on close out piece to look inside and ensure engagement.

(p) Install plastic retainer clips in location “zz” previously extracted.

(q) Insert 1 u-nut per side over hole drilled on fender well in step (i) and in between the fender and skirt. (flat side towards skirt)

NOTE: A gap of less than 2mm between fender and skirt (red oval Fig.5-11) will be present due to the u-nut.

(r) Locate the two 6.3x 20mm self tapping screw from hardware bag and install into the fender well through the skirt and u-nut. Fig.5-11 in both locations.

NOTE: make sure the “Close out grey u-nut” is properly located between fender and Skirt.

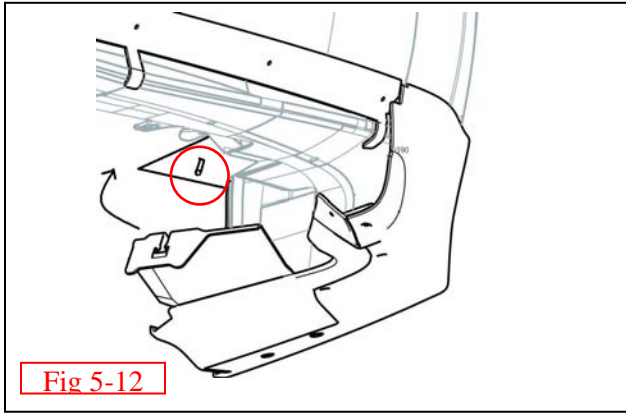

(s) RHS skirt is the same except there are no push pins; they are replaced by the Plastic Wing Nut that was extracted earlier from OE hardware bag . Rotate hinged part upward into proper position under vehicle stud and install plastic wing nut.(Fig 5-11)

(t) Once the both close out pieces are installed locate plastic retainer clips the fasteners that were removed from the lower spoiler earlier and re-install in 4 places (a) as shown in Fig.5-13. Locate 2 plastic clips and install in positions (b), make sure that skirt and close out piece are aligned before inserting the clip. Pinch them together to ensure appropriate engagement

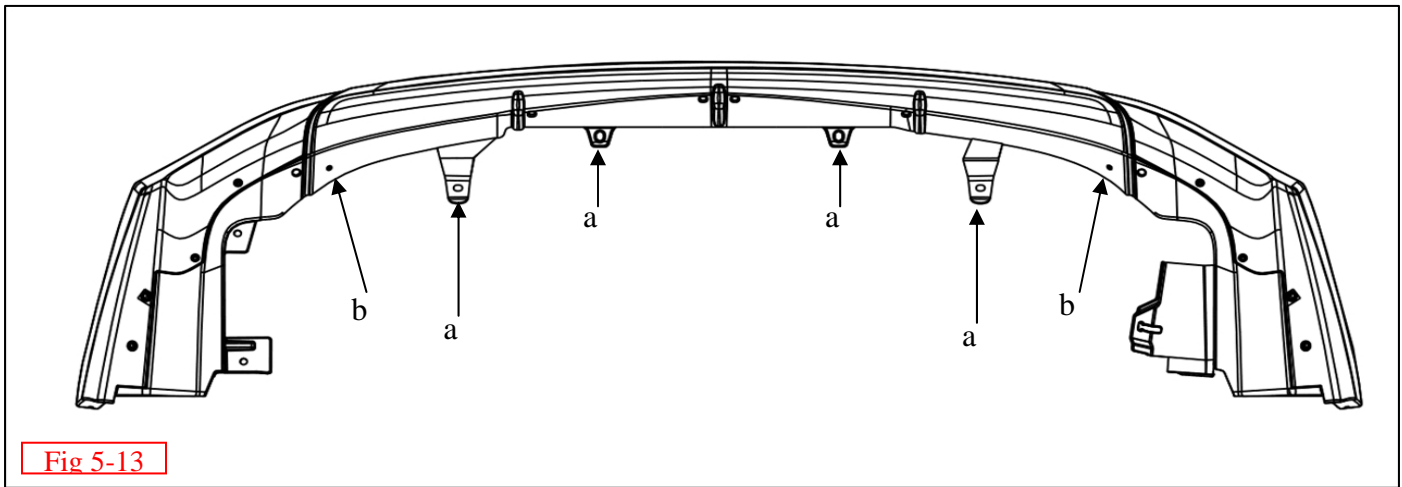

(u) Tighten all hardware, making sure they sit flush to the part.

Checklist - these points **MUST** be checked to ensure a quality installation.

Check:

Look For:

Accessory Function Checks

- Visual check of skirts
 - Make sure all fasteners are in place
 - Check for overall appearance

Check to ensure there are no gaps between the rubber seal (gasket) and the vehicle surface.

Check if brackets are engaged by lightly tapping on the skirts and listening for looseness.

-  Re-check all screws

Preparation

Side Skirts

Kit Contents

Item #	Quantity Reqd.	Description
1	1	LHS Skirt Assembly
2	1	RHS Skirt Assembly
3	1	LHS Mud Guard
4	1	RHS Mud Guard

Hardware Bag Contents

Item #	Quantity Reqd.	Description
1	18	Push Pin Fasteners
2	8	Installation plugs
3	2	Plastic clip

Additional Items Required For Installation

Item #	Quantity Reqd.	Description

Conflicts

--

Recommended Tools

Personal & Vehicle Protection	Notes
None	
Special Tools	Notes
None	
Installation Tools	Notes
Plastic Pry tool	To remove push pins
10mm socket	Ratchet
10mm ratchet wrench	
Philips Screwdriver	
Special Chemicals	Notes
None	

General Applicability

--

Recommended Sequence of Application

Item #	Accessory
1	
2	
3	

*Mandatory





Care must be taken when installing this accessory to ensure damage does not occur to the vehicle. The installation of this accessory should follow approved guidelines to ensure a quality installation.

NOTE: Part number of this accessory may not be the same as the part number shown.

Vehicle Service Parts (may be required for reassembly)

Item #	Quantity Reqd.	Description
1		
2		
3		

Legend

	STOP: Damage to the vehicle may occur. Do not proceed until process has been complied with.
	OPERATOR SAFETY: Use caution to avoid risk of injury.
	CAUTION: A process that must be carefully observed in order to reduce the risk of damage to the accessory/vehicle and to ensure a quality installation.
	TOOLS & EQUIPMENT: Used in Figures calls out the specific tools and equipment recommended for this process.
	REVISION MARK: This mark highlights a change in installation with respect to previous issue.

TOYOTA PRIUS GROUND EFFECTS 2012 -

Procedure

These guidelines can be found in the "Accessory Installation Practices" document.

This document covers such items as:-

- Vehicle Protection (use of covers and blankets, cleaning chemicals, etc.).
- Safety (eye protection, rechecking torque procedure, etc.).
- Vehicle Disassembly/Reassembly (panel removal, part storage, etc.).
- Electrical Component Disassembly/Reassembly (battery disconnection, connector removal, etc.).

Please see your Toyota dealer for a copy of this document.

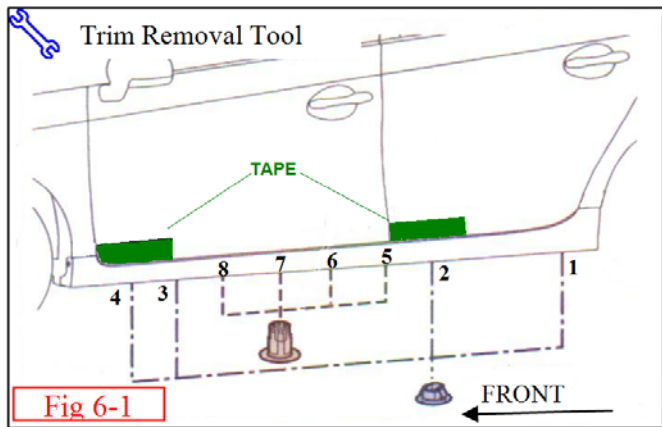

6. Remove Factory Skirt.

- (a) Place protective tape on bottom of door to prevent scratching. To remove existing skirt, go to underside of vehicle (Fig 6-1)
- (b) Remove the 4 plastic plugs (Fig 6-1) positions 1,2,3,& 4. Discard plugs.

- (c) Using the trim removal tool pop large push pins and pull down from vehicle. (Fig 6-1) Positions 5, 6,7,& 8. **Keep these parts for later re-installation.**



- (d) Using a 10mm socket, remove screws from locations shown. (Fig 6-2) **Keep these parts for later re-installation.**



- (e) Using a 10mm socket, remove screws from locations shown. (Fig 6-3) **Keep these parts for later re-installation.** Remove the fastener from location E, using the trim removal tool (can be cut). The mud flap will now be free from the vehicle and can be discarded.

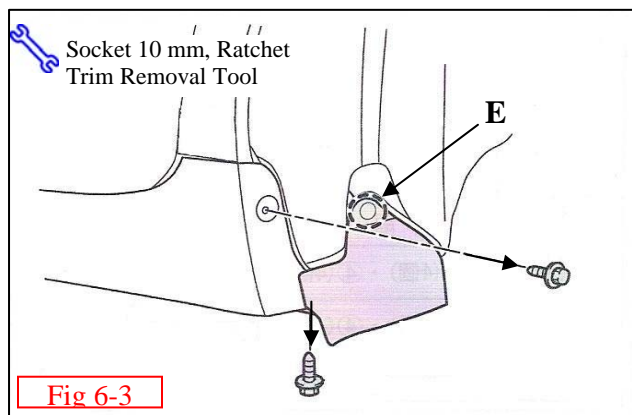
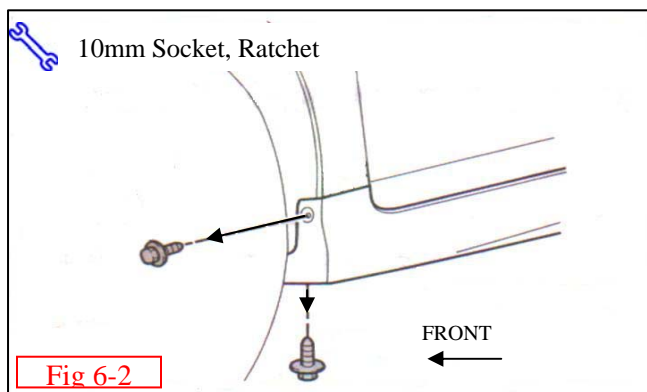

TOYOTA PRIUS GROUND EFFECTS 2012 -

Procedure

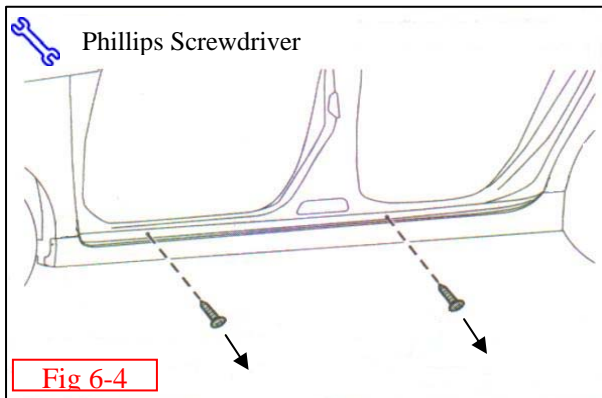

- (f) Using a Phillips screwdriver locate and remove 2 Phillips head screws from locations Shown. (Fig 6-4) **Keep these parts for later re-installation.**



- (g) Gently pull the skirt away from the vehicle, starting at the rear and working your way to the front. The skirt will now be free from the vehicle and can be discarded



NOTE: Make sure no fasteners remain on the vehicle

- (h) Repeat For the Right Hand Side

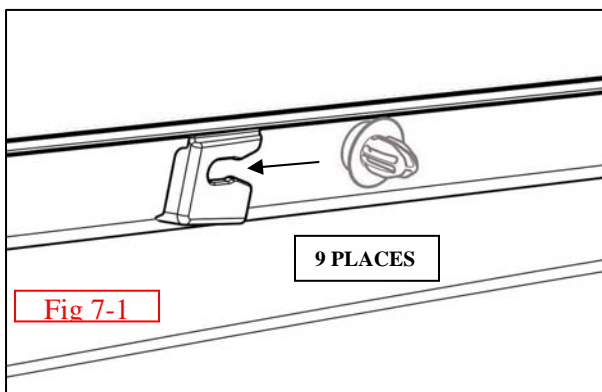

7. Skirt Installation

- (a) Locate new clips from the hardware pack. Install in 9 locations as shown in figures 7-1 & 7-2. Ensure the fasteners are snapped into place and float inside their respective holes with out falling out.

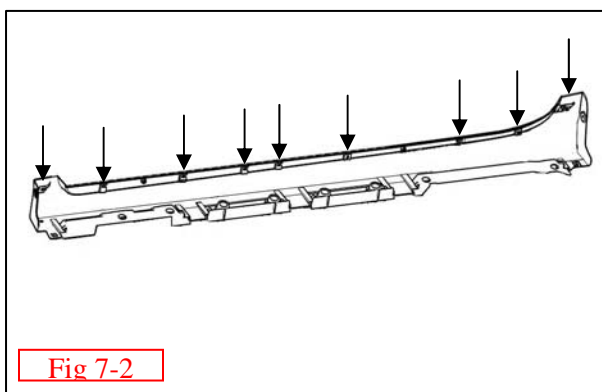

- (b) Once the skirt is assembled. Place the skirt into position, lining up recently snapped in fasteners with vehicle holes. Starting from the center and working outwards, push on each fastening area using medium force. There should be an audible sound of the fasteners engaging to the vehicle.

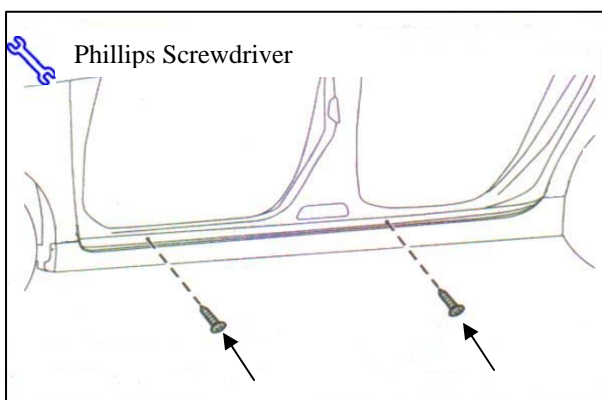

- (c) Replace the 2 Phillips head screws that were removed earlier. (Fig 7-3)

TOYOTA PRIUS GROUND EFFECTS 2012 -

Procedure

Fig 7-3

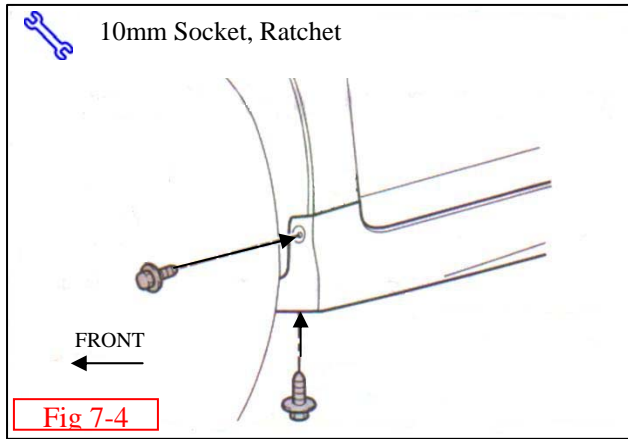

- (d) Replace the 10mm head screws that were removed earlier from the front of the factory skirt. Ensure the lower underbody shield is sitting on the outside surface of the skirt underside and that the holes are aligned before installing the screws. Tighten fasteners. (Fig 7-4)

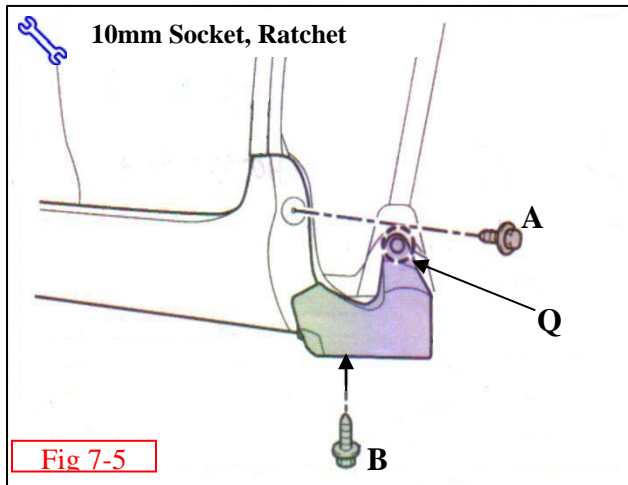

- (e) Install 10mm screw "A" removed earlier (Fig 7-5) and tighten fastener.
- (f) Locate new mud flap from packaging and install using the 10mm screw "B" removed earlier and tighten 10mm Fastener.(Fig 7-5)
- (g) Install clip (position Q Fig 7-5) through mud flap and into vehicle mount.

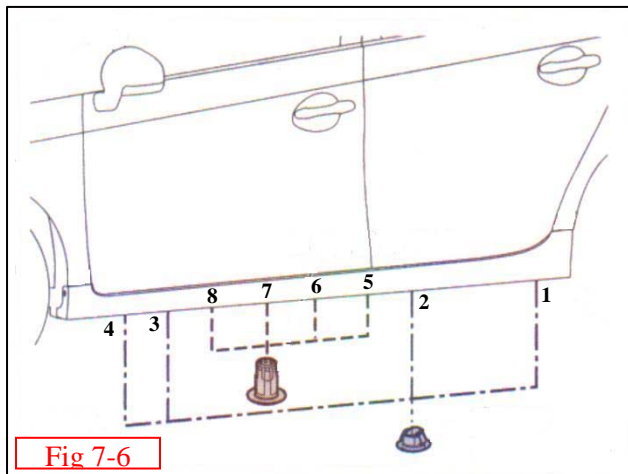

- (h) Locate replacement installation plugs and install in positions 1,2,3, & 4 (Fig. 7-6)
- (i) Locate large push pin fasteners from earlier removal and install in positions 5,6,7, & 8. (fig. 7-6)
- (j) **Repeat For Right Hand Side**

TOYOTA PRIUS GROUND EFFECTS 2012 - Procedure

Accessory Function Checks

Visual check of skirt

Insure Fasteners are completely engaged to
vehicle.

 Re-check all screws